

7

6

5

4

3

2

1

Gas Train Detail

Item	Req	Description
1	2	Main Gas Shutoff Valve
2	1	Gas Valve Actuator (w/o POC)
3	1	Gas Valve Regulating Actuator (w/ POC)
4	1	Gas Pilot Valve
5	1	Pilot Pressure Regulator *
6	1	Pilot Pressure Gauge
7	1	Low Gas Pressure Switch MR
8	1	High Gas Pressure Switch MR
9	1	Pilot Gas Cock
10	1	Butterfly Valve
11	2	Test Cock

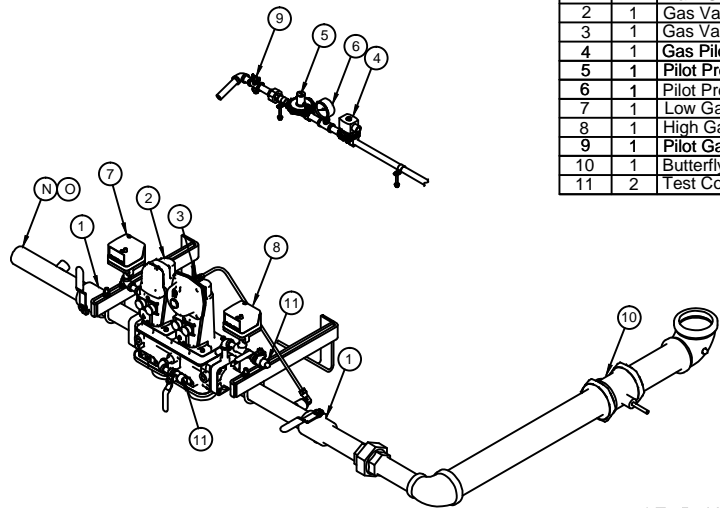

* To Be Vented To Safe Point Of Discharge

Oil Piping Detail

Item	Req	Description
1	2	Solenoid Valve
2	2	Relief Valve
3	1	Fuel Oil Controller
4	1	Low Oil Pressure Switch
5	2	Pressure Gauge
6	1	Fuel Oil Filter

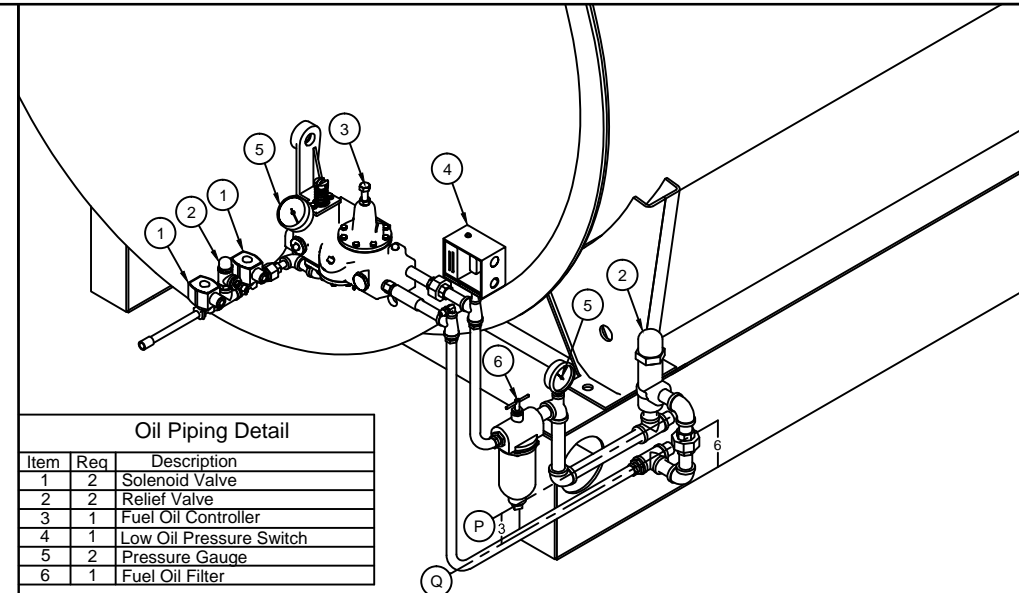

Bottom Blowdown Detail

Item	Req	Description
1	1	Slow Opening Blowdown Valve - Tecval VP250 - SO 2.0 NPT
2	2	Quick Opening Blowdown Valve - Tecval VP250 - QO 2.0 NPT

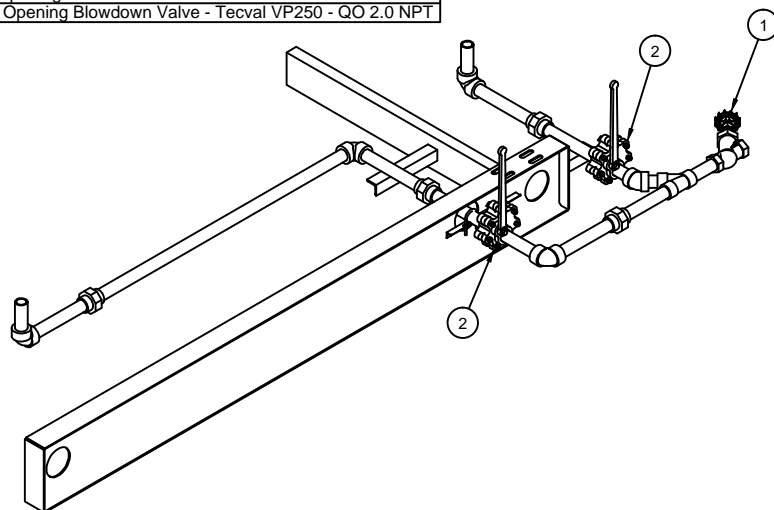

Surface Blowoff Detail

Item	Req	Description
1	1	Gate Valve .75 NPT
2	1	Electrode Probe
3	1	Advantage Motorized Valve .5 NPT
4	2	Gate Valve .25 NPT
5	1	Flowcontrol Valve .75 NPT
6	1	Sample Cooler

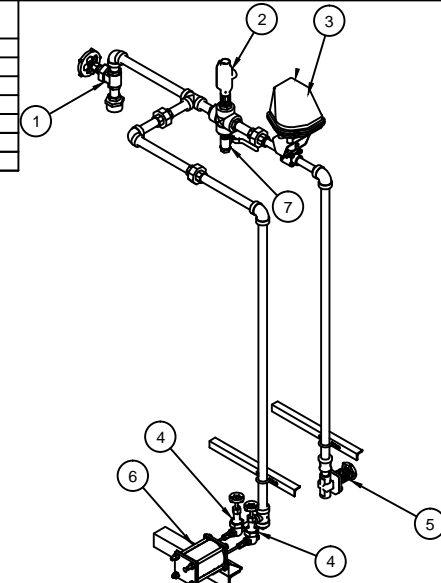

Ship Loose

These Items Are Shipped Loose For Installation By Others

Safety Valve - (2) Set At 150#

Oil Pump Set - (1) TUTHILL 2LE-A 3/4 HP 270 GPH 1725 RPM

Fuel Oil Pump Set - Tuthill

Model: 2LE-A Motor: 3/4 HP Capacity: 270 GPH

Notes
 Assembly To Be Shipped Loose
 Normal Pump Operating Discharge Pressure 100 PSIG
 Maximum Recommended Pump Suction 12 Inches Of Mercury
 Pump Assemblies Include Suction Strainer, Magnetic Starter & Hand - Off Automatic Switch
 Pump Set To Be Installed Close To Oil Storage Tank
 Oil Flow Can Be In Either Direction

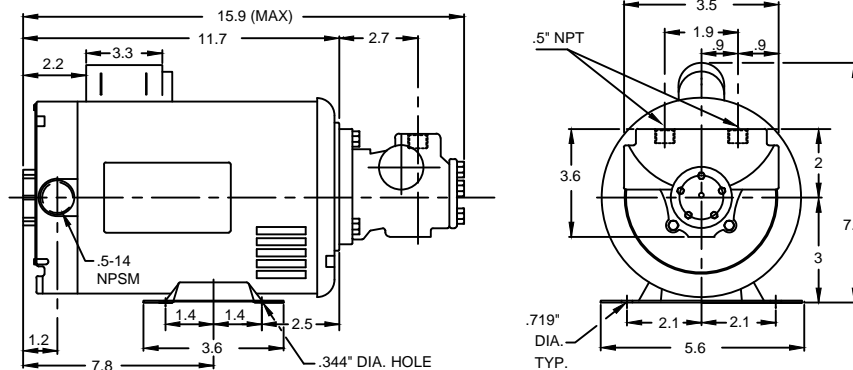

CAUTION

DIMENSIONS SHOWN ARE APPROXIMATE AND SHOULD NOT BE USED IN RESTRICTIVE LAYOUTS OR TO PREFABRICATE ASSEMBLIES UNLESS CLEAVER-BROOKS HAS BEEN CONSULTED. IT IS STRONGLY RECOMMENDED THAT THE CUSTOMER REQUEST AS-BUILT CERTIFIED DRAWINGS FOR THESE CASES.

WARNING

LIFTING LUGS PROVIDED ON THE VESSEL SHALL ONLY BE USED TO LIFT THE VESSEL WHEN IT IS DRY.

WARNING

CHANGES, MODIFICATIONS OR ALTERATIONS ARE STRICTLY PROHIBITED.

CHANGES TO THIS DRAWING AND SUBSEQUENT MODIFICATION OF EQUIPMENT COULD RESULT IN DAMAGE TO THE EQUIPMENT AND/OR SERIOUS PERSONAL INJURY.

PRELIMINARY

DIMENSIONAL DIAGRAM

SIZE D

SHT 02 OF 02

SCALE N.T.S.

DATE 12/21/11

DRAWN H L J

CHECKED BY M S T

CleaverBrooks

MODEL	FUEL SIZE	400	150ST	CAPACITY
CBEX ELITE	200	400	150ST	
460	3	60	3	N/A
VOLTS	PHASE	HERTZ	WIDE	INSURANCE

DRWG. NO. CBEX ELITE 400 HP 150 00

THIS DRAWING IS PROPERTY OF CLEAVER-BROOKS DIVISION IT IS SUBJECT TO CHANGE WITHOUT NOTICE, AND IS NOT TO BE COPIED OR USED IN ANY WAY DETRIMENTAL TO THE COMPANY.

REVISIONS

00